

Spray Dryers

Explosion Suppression Systems

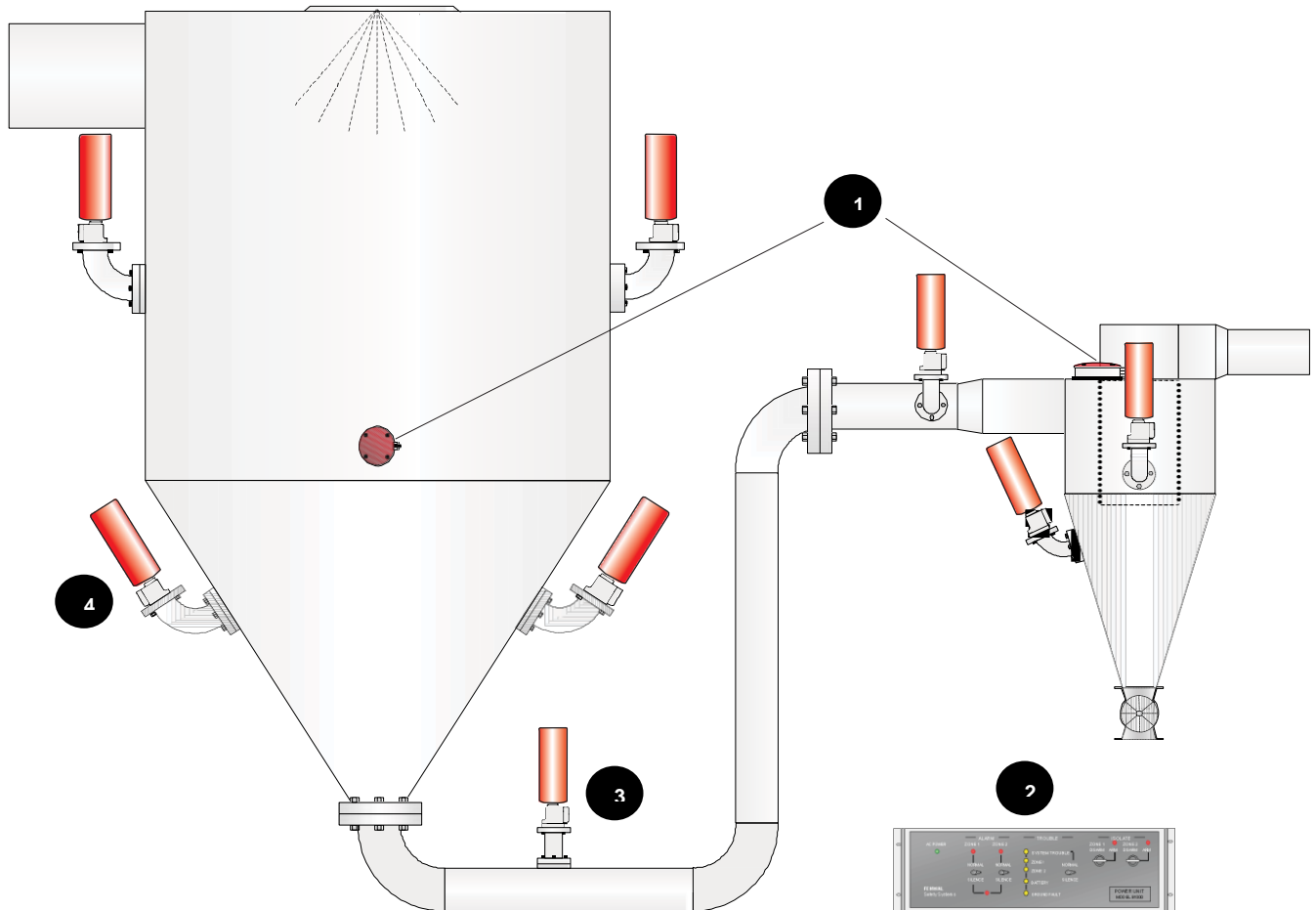

Application

In a typical spray drying system an organic aqueous slurry enters the drying vessel via a spray nozzle. As the atomized cloud of material falls under the influence of gravity, an incoming stream of hot air dries it. The dried material leaves the hopper section where it may be further dried or cooled by a fluid bed dryer/cooler before entering a dust separator such as a dust collector or a cyclone (as shown). Multiple separators may be used.

System Components

- ① **Pressure Detector**
- ② **Two Zone Control Panel**
- ③ **Isolation Suppressor**
- ④ **HRD Suppressor**

Hazard

Typically a spray drying system represents a large volume of potentially explosive material. Although the material enters the dryer as a wet spray, it dries quickly to become more sensitive to ignition. This ignition can be provided by incoming burning particles from a gas or oil fired heater. Ignition can also come from downstream process components and from auto-ignition of material deposits within the dryer

Protection System Considerations

Protection systems for drying systems must accommodate the need to maintain smooth inside vessel walls. This is to prevent product buildups and for efficient cyclone performance. IEP Technologies suppression systems achieve this by using flush spreader assemblies for suppressant dispersal.

Protection System Description

Drying systems are typically in two sections. The first section dries the material. The second section separates the dry material from the air stream. Consequently the explosion suppression system used is typically a two-zone system. The drying vessel and the dust separation vessel(s) have protection zones that operate independently of each other while providing isolation barriers to mitigate explosion propagation between interconnected vessels. In such a system, explosion pressure detectors mounted on the dryer and dust separator (such as a cyclone), detect the pressure excursion from an impending explosion. The detectors transmit a signal to the control panel. This triggers high rate discharge suppressors in the affected zone which rapidly discharge suppressant in an effort to quench the fireball before maximum explosion pressures are reached. Isolation suppressors mounted on the ducts reduce the risk of explosion propagation to interconnected process equipment. The control unit also shuts down the process automatically, mitigating the transfer of burning materials, dust, and air.

Typical Installation Details

Extinguisher Flush Spreader

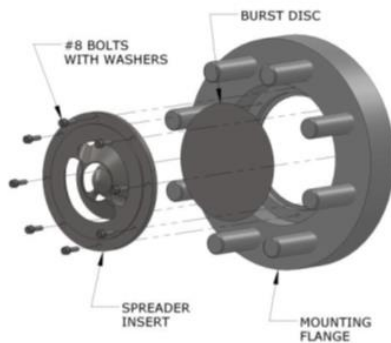

Dynamic Pressure Detector

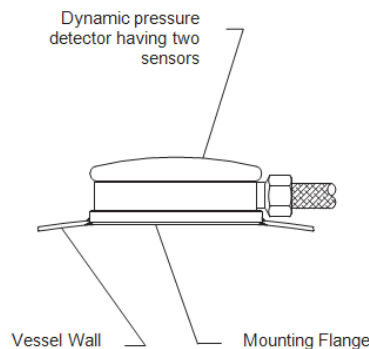

Ordering Information

For additional information, please contact one of the following locations:

IEP Technologies

United States: Tel: +1 (855) 793 8407

United Kingdom: Tel: +44(0) 1242 283 060

Switzerland: Tel: +41 (0) 62 207 10 10

Germany: Tel: +49 (0) 2102 5889 0