

## Dust Collectors

### Explosion Relief Venting Systems

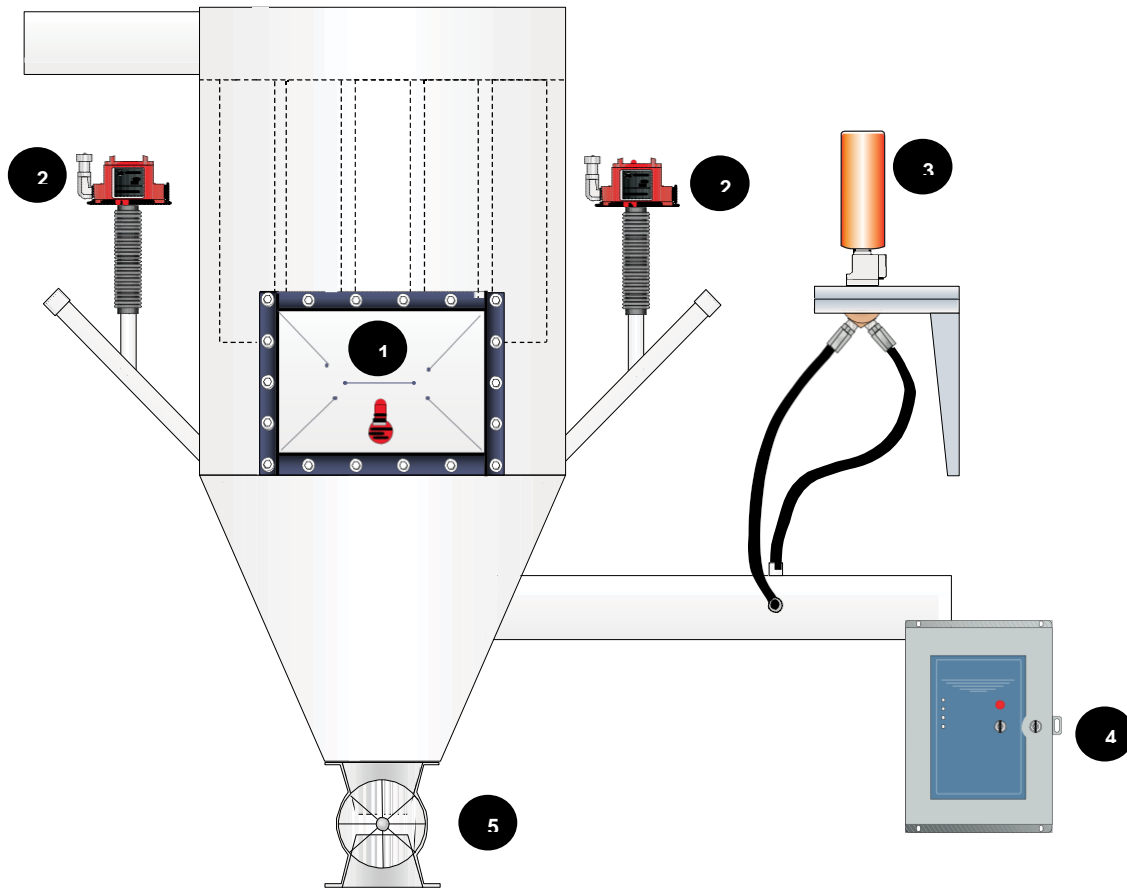

### Application

Dust collectors are typically used as receiving vessels or for the collection of dust. They separate dust from the air stream by employing an array of filter bags or filter cartridges. Dust-laden air slows down as it enters the collector, shedding some of its dust load into the collection hopper which may empty via a rotary gate valve. The lighter dust is swept up into the filter components from which it is periodically removed by air blasts or by a shaker mechanism.

### System Components

- ① **Explosion Relief Vent Panel**
- ② **Pressure Detector**
- ③ **Isolation Suppressor**
- ④ **Single Zone Control Panel**
- ⑤ **Rotary Gate Valve (by others)**

## Hazard

Dust collectors collect the finest and therefore the most readily ignited dust in a process, making them the most commonly protected process vessels. Even dust collectors handling dust loadings below the explosible limit may generate explosive dust levels when their filter components are periodically cleaned by shaker mechanisms or by jets of air. Under these conditions, an ignition source is all that is required to initiate an explosion. This ignition source can be provided by electrostatic discharge or by incoming burning particles from upstream equipment such as mills or dryers. In addition to damaging the dust collector, the explosion may propagate to connected equipment.

## Protection System Description

For dust collectors mounted outside or close to an outside wall, explosion relief venting is a viable protection method. Protection is provided by an explosion relief vent that ruptures at a predetermined burst pressure to relieve pressure caused by an explosion. Since the vent releases the pressure only, it is vital that the protection method includes a means to mitigate propagation of flame and burning materials. To achieve this, explosion pressure detectors mounted on the collector detect the pressure excursion from an incipient explosion. The detectors transmit a signal to the control panel, which triggers a high rate discharge suppressor while simultaneously shutting down the process. The suppressor, which is mounted on the inlet duct, reduces the risk of explosion propagation upstream to interconnected process equipment. An explosion-proof rotary gate valve reduces the likelihood of burning materials passing downstream.

## Typical Installation Details

### Explosion Relief Vent

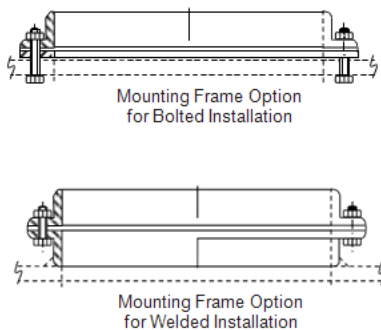

### Duct Isolation Components

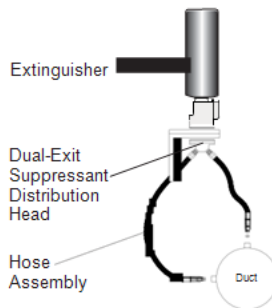

### Pressure Detector

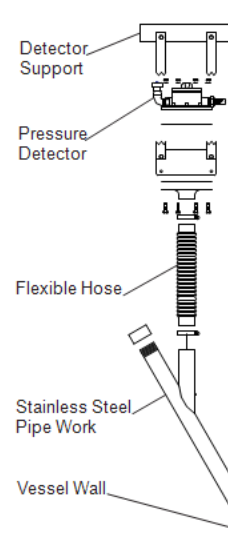

## Ordering Information

For additional information, please contact one of the following locations:

### IEP Technologies

United States: Tel: +1 (855) 793 8407

United Kingdom: Tel: +44(0) 1242 283 060

Switzerland: Tel: +41 (0) 62 207 10 10

Germany: Tel: +49 (0) 2102 5889 0